

Backside parts glued to front & back plate

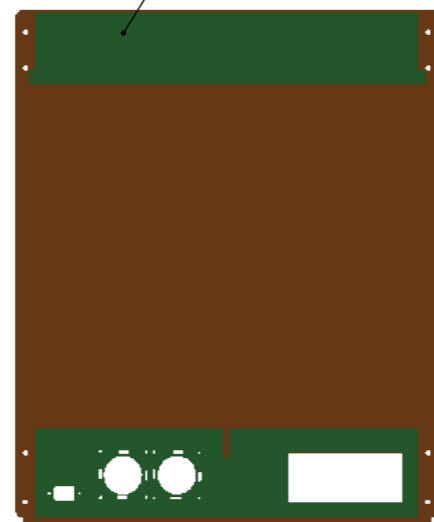

Part nr.	Part	Size in mm	Quantity	Material
F-1 & B-1	Front & Back plate	560 x 680 x 9	2	MDF
F-2 & B-2	Front & Back inner #1	506 x 117 x 9	2	MDF
F-3	Front inner #2	506 x 36 x 9	1	MDF
F-4	Front inner #3	510 x 75 x 9	1	MDF
F-5	Front inner #4	475 x 41 x 9	2	MDF
B-3	Back inner #2	524 x 93 x 9	1	MDF
B-4	Bottom plate	540 x 627 x 9	1	MDF
T-1	Top plate	524 x 627 x 5	1	Birch triplex
T-2	Support spar	524 x 22 x 10	1	Pine
M-1	Machine plate	524 x 618 x 9	1	MDF
M-2	Support small	524 x 117 x 9	1	MDF
M-3	Support long	628 x 117 x 9	1	MDF

	ONDERWERP: Stepcraft 420 Enclosure				
	GETEKEND MET:	NAAM	DATUM	REVISIE	DATUM
FINISH:	GETEKEND DOOR: CNCMiller	5-8-2017			
MATERIAAL:	GECONTROLEERD:				
GEWICHT:	TEKENING ONDERDEEL & Nr.: Enclosure overall & front/Back			A3	
	SCHAAL: 1:10	TEKENING: 1 of 2			

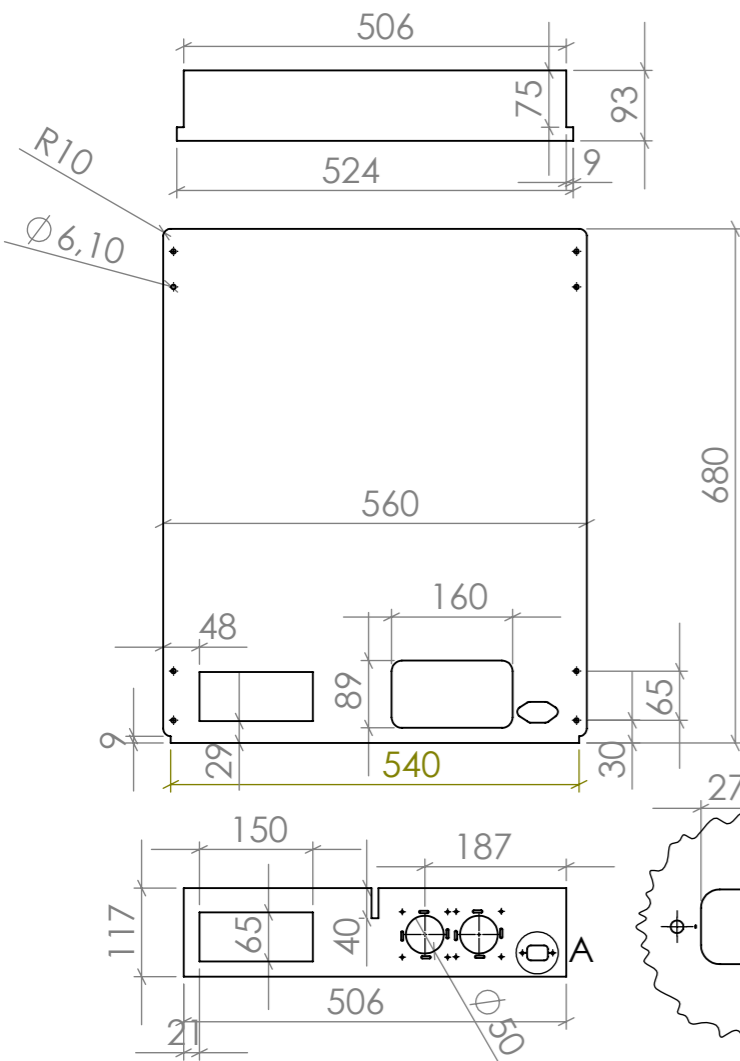
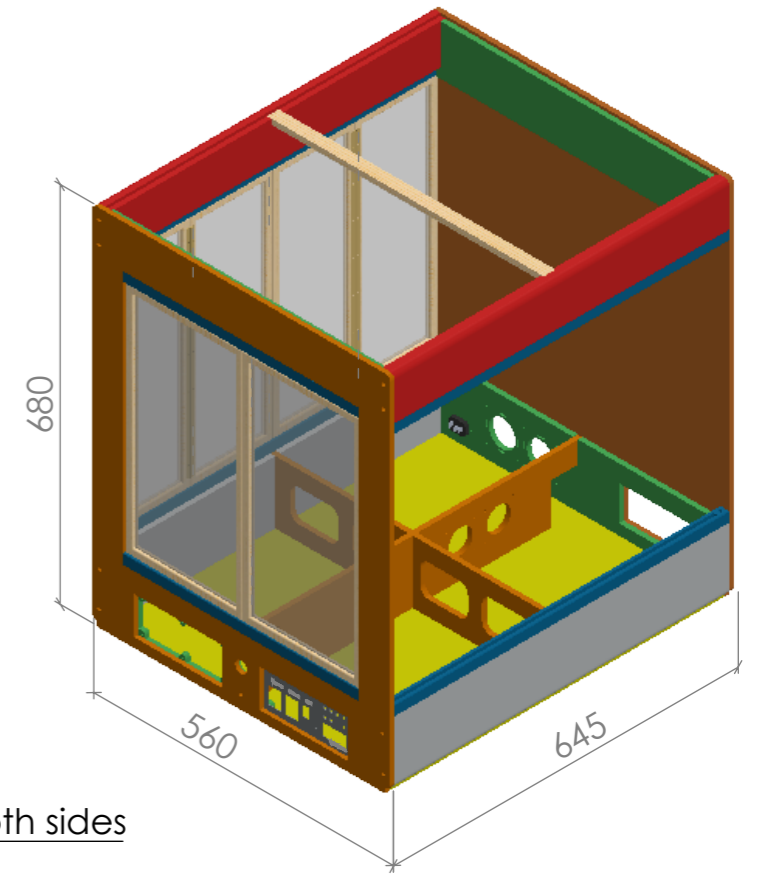
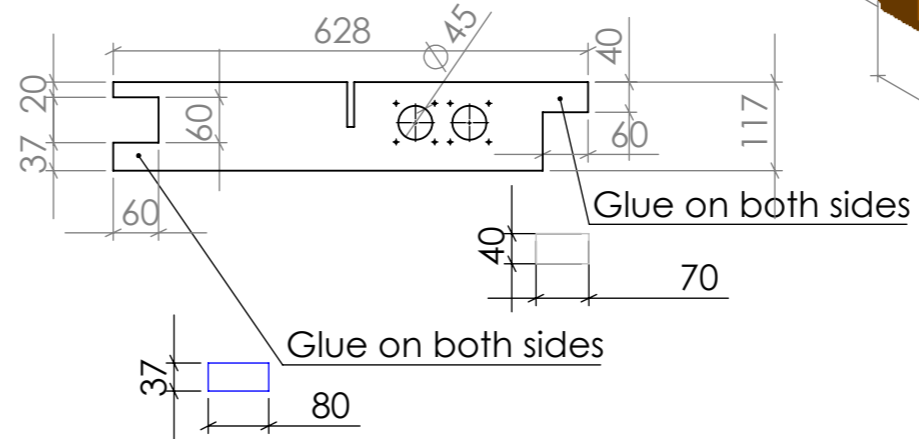
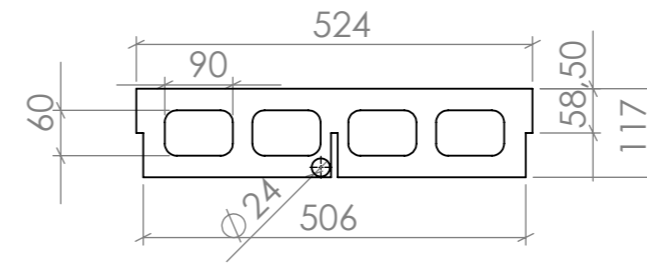
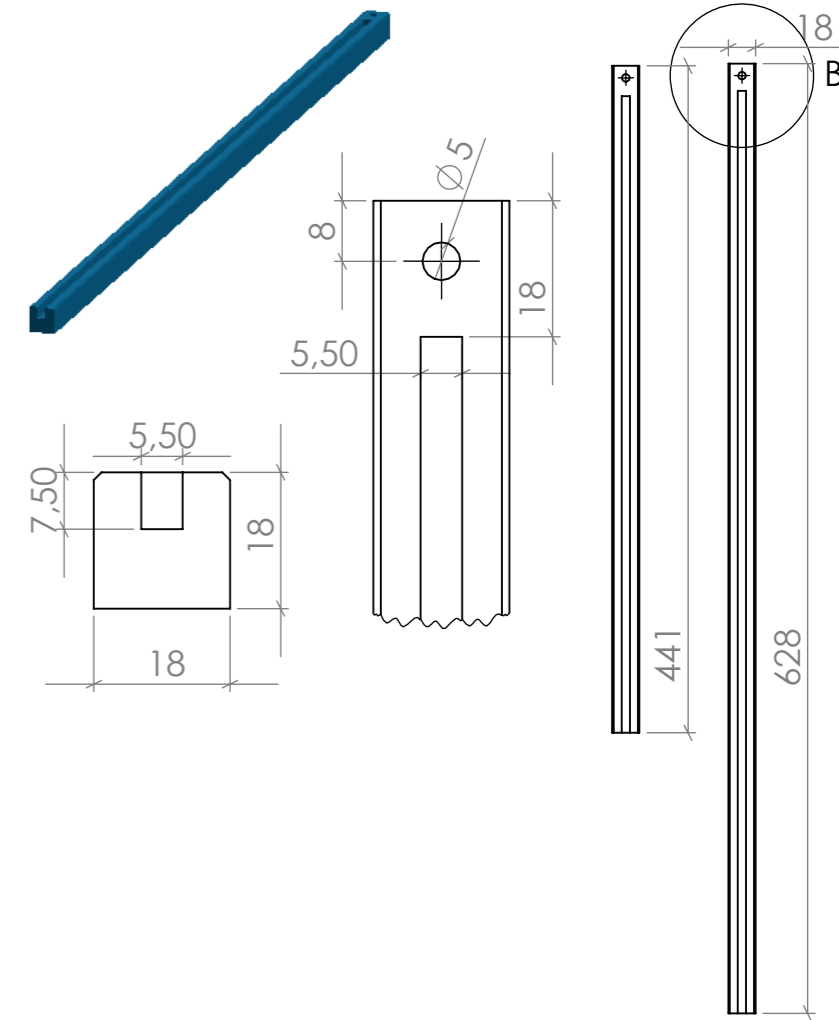
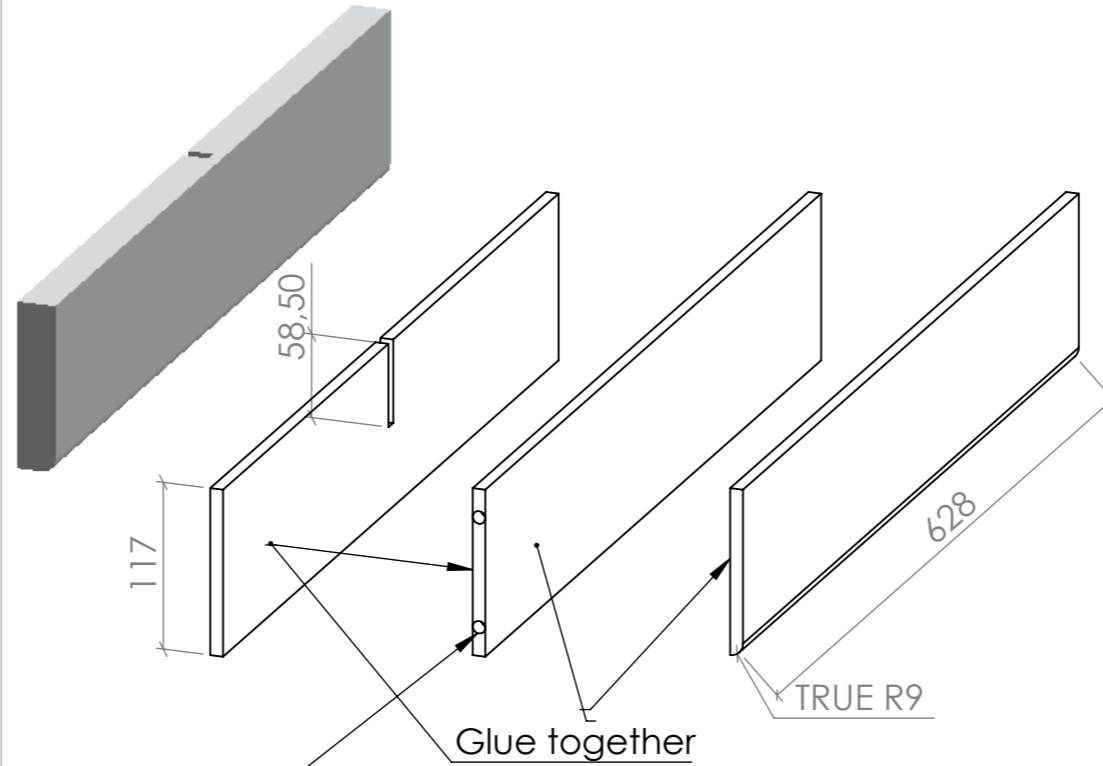
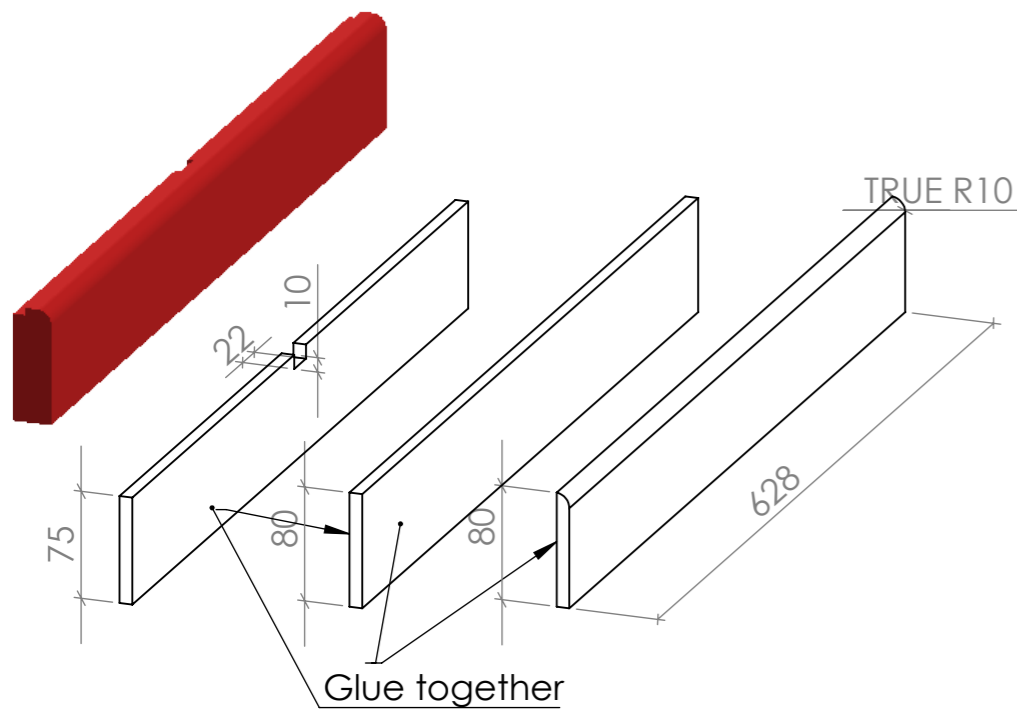

drill holes after assembly for rivet nuts

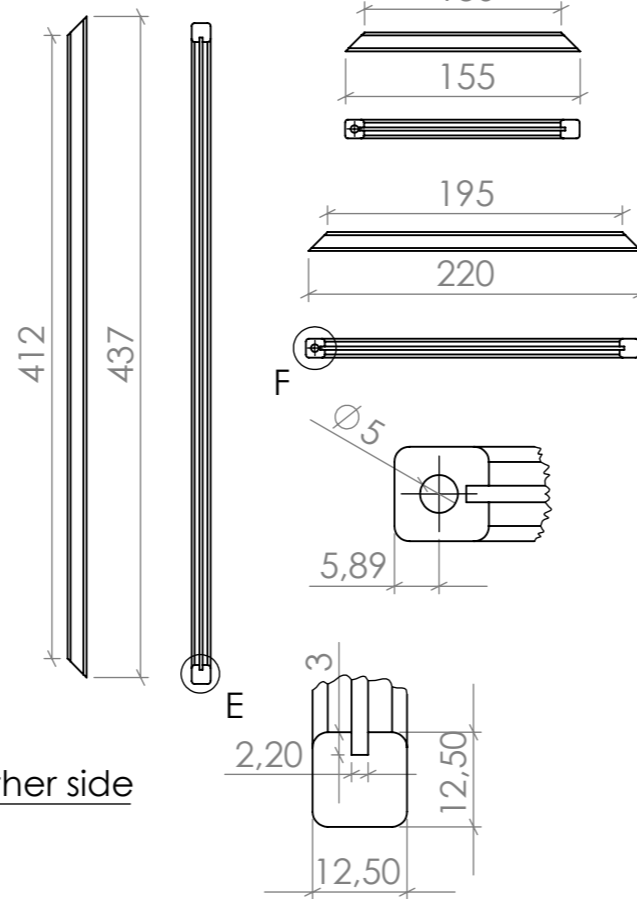
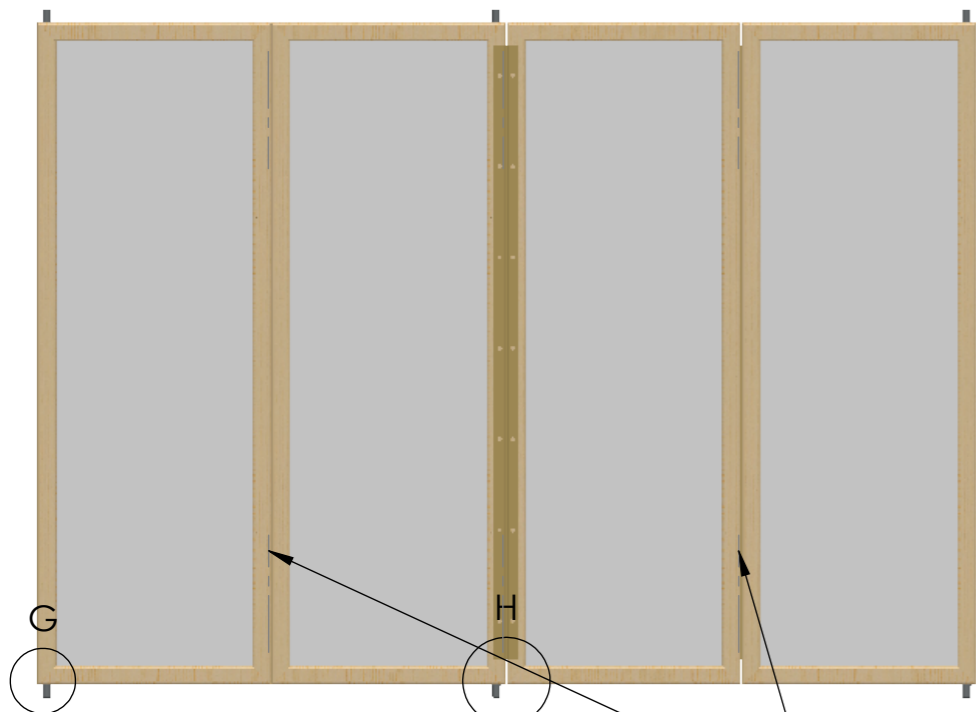

Hinge on other side

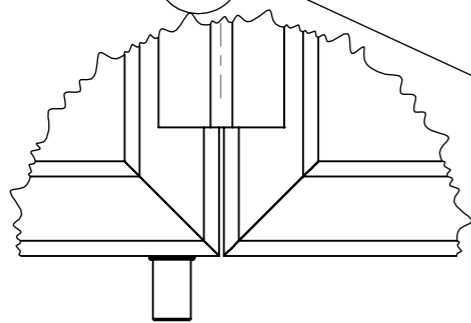
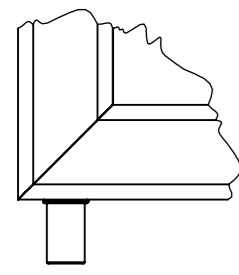

Part nr.	Part	Size/Dimensions	Quantity	Material
S-1	Beam top	628 x 80 x 9	4	MDF
S-2	Beam top	628 x 75 x 9	2	MDF
S-3	Beam bottom	628 x 117 x 9	6	MDF
R-1	Door rail sides	628 x 18 x 18	4	Pine
R-2	Door rail front	441 x 18 x 18	2	Pine
D-1	Acrillic sides		8	Arcillic/Persplex
D-2	Acrillic front		2	Acrillic/Persplex
D-3	Doorpost large	437 x 12.5 x 12.5	20	Pine
D-4	Doorpost small	155 x 12.5 x 12.5	16	Pine
D-5	Doorpost medium	220 x 12.5 x 12.5	4	Pine
D-6	Continuous hinge	405 x 20 x 0.7	7	Brass
D-7	Shelf support	16.5 x 5 diameter	14	Metal
H-1	Rivet nut	M6 15 x 9	16	drill 8.9
H-2	Button head screw	M6 22 long	16	



ONDERWERP: Stepcraft 420 enclosure

GETEKEND MET:	NAAM	DATUM	REVISIE	DATUM
GETEKEND MET:		5-8-2017		
FINISH:	GECONTROLEERD:			
MATERIAAL:	TEKENING ONDERDEEL & Nr.: Doors			A3
GEWICHT:	SCHAAL: 1:5	TEKENING: 2 of 2		